

**AV-700 - VOLVO - TWD 1643 GE**

**1.500 R.P.M. | 50 Hz**

## TECHNICAL SPECIFICATIONS



Model:

**AV-700**

Gen set with manual control panel.

Image for guidance purposes.

ENGINE	MAKE	MODEL
	VOLVO	TWD 1643 GE
ALTERNATOR	MODEL	
	MECC-ALTE ECO40-2L/4	

(400 / 230 V)

CONTINUOUS POWER: (PRP "Prime Power" norma ISO 8528-1)	<b>630 kVA</b>
STAND-BY POWER: (LTP "Limited Time Power" norma ISO 8528-1)	<b>700 kVA</b>

### Amperes in the different voltages:

VOLTAGE	HZ	PHASE	COS Ø	PRP KVA/KW	LTP KVA/KW	AMPERAGE
415/240	50	3	0,8	636,5/509,2	707,8/566,2	985,79
400/230	50	3	0,8	636,5/509,2	707,8/566,2	1022,76
380/220	50	3	0,8	636,5/509,2	707,8/566,2	1076,59
240/139	50	3	0,8	636,5/509,2	707,8/566,2	1704,6
230/133	50	3	0,8	636,5/509,2	707,8/566,2	1778,71
220/127	50	3	0,8	636,5/509,2	707,8/566,2	1859,56

**ELECTRO EXIM SRL**

**ELECTRO EXIM SRL**  
21 Ialomicioarei St., sector 1, code 011277, BUCHAREST - ROMANIA  
Phone: 0040 21 2231347 - 0040 744 755 390 - FAX: 0040 21 2231201  
E-mail: office@electroexim.com - Web: www.electroexim.ro

**AV-700 - VOLVO - TWD 1643 GE**

**1.500 R.P.M. | 50 Hz**

## ENGINE CHARACTERISTICS

MAKE	MODEL
VOLVO	TWD 1643 GE

### GENERAL DATA

Power PRP (kWm)	536
Power LTP (kWm)	596
No. cylinders	6
Cylinder capacity (L)	16.12
Diameter per stroke (mm)	144 x 165
Compression ratio	16.50
Cooling system	LIQUID
Injection	COMMON RAIL
Suction	TURBO-INTERC.
Series regulator	ELECTRONIC
Fly wheel coupling	1-14"

### Lubrication system

Oil capacity (L)	48
Oil consumption (%)	0.08
Min. alarm oil pressure (bar)	2.20

### Ventilation system

Air cooling flow (m3/h)	46800
Combustion air flow (m3/h)	2640
Max. back pressure for fan (mbar)	0

### Exhaust system

Exhaust gas flow (m3/h)	6096
Exhaust back pressure (mbar)	100
Temp. exhaust gases (°C)	450

### Electrical system

VDC (V)	24
Battery (Ah)	2 x 180
Engine start-up (kW)	7

**ELECTRO EXIM SRL**

**ELECTRO EXIM SRL**  
21 Ialomicioarei St., sector 1, code 011277, BUCHAREST - ROMANIA  
Phone: 0040 21 2231347 - 0040 744 755 390 - FAX: 0040 21 2231201  
E-mail: office@electroexim.com - Web: www.electroexim.ro

**AV-700 - VOLVO - TWD 1643 GE**

**1.500 R.P.M. | 50 Hz**

## ALTERNATOR CHARACTERISTICS

### MODEL

MECC-ALTE ECO40-2L/4 (400 / 230 V)

### GENERAL DATA

Power PRP (kVA)	680.00
Power LTP (kVA)	748.00
Efficiency Alt. 3/4 %	95.20
Efficiency Alt. 4/4 %	95.00
No. Poles	4
Voltage regulator	DER-1
No. wires	12
Insulation	H
Xd (%)	227.00
X'd (%)	18.10
X	9.20
Degree of protection	IP21

## GENERATOR SET CONSUMPTION

% POWER USED	LITRES/HOUR
50%	59
75%	89
100%	120

## DIMENSIONS, CAPACITIES, APPROXIMATE WEIGHT AND NOISE

LENGTH	DIMENSIONS (MM)	
	WIDTH	HEIGHT
3500	1330	2506
FUEL TANK (LITRES)		WEIGHT (KG)
1023		-
NOISE LEVEL (dB (A))		

**AV-700 - VOLVO - TWD 1643 GE**

**1.500 R.P.M. | 50 Hz**

## **INMESOL GENERATOR SET**

### **GENERAL DESCRIPTION**

The "INMESOL" generator set is an electrical energy generating machine which is used in places where there **is no mains supply** or when there is a MAINS failure.

The mobile elements, distribution belt, fan, etc., and those parts which reach high temperatures during operation, exhaust manifold, etc, include their corresponding protections, in compliance with the requirements of the Machinery Directive **2006/42**.

### **REGULATIONS**



The machine holds the "CE" marking, and the corresponding Declaration of Conformity is issued with each of them, in which it specifies that the machine complies with **R.D 842/2002 Low Voltage Regulations and with the European Directives:**

- 2006/42 on Safety in Machinery.
- 2006/95/CE on Electrical Safety.
- 2004/108/CE on Electromagnetic Compatibility.
- 2005/88/CE on NOISE EMISSIONS by equipment for outdoor use (for SOUNDPROOF GENERATOR SETS).

**AV-700 - VOLVO - TWD 1643 GE**

**1.500 R.P.M. | 50 Hz**

**IN INDUSTRIAL RANGE / SCOPE OF SUPPLY**

		
Engine/alternator monobloc directly connected and installed via silent blocks on a frame made from high tensile electro welded steel profiles that are treated with degreasing liquids and aplicated with a phosphate coat and epoxi paint.	✓	✓
Canopy of steel sheet sound proofed with fireproof rockwool, and treated with degreasing liquids and aplicated with a phosphate coat and epoxi paint.	•	✓
Fuel tank integrated in the base frame provided with fuel level jauge and fuel connections to the engine.	✓	✓
Engine with mechanical engine driven pusher fan.	✓	✓
Industrial silencer with -15 db(A) noise reduction and exhaust outlet tube.	✓	•
Residencial silencer with -35 db(A) noise reduction with exhaust tube and protection cap.	•	✓
Electric control cubicle with control module including protection and reading of electrical meassures engine instrumentation fuel level and engine running hours, etc.	✓	✓
Termal and magnetic circuit breaker and termal and magnetic circuit breaker and earth fault relay.	✓	✓
Battery charge alternator.	✓	✓
Starter battery complete with cables to the engine and pole protection.	✓	✓
Installation prepared for earthing spike (spike not included).	✓	✓
Security protection for heat and moving parts as well as live electrical components.	✓	✓
External emergency stop push button.	✓	✓
Manual engine oil extraction pump.	•	✓
Self excited and auto regulated alternator.	✓	✓
Integrated lifting hook for single point lifting with crane, gensets up to 450 kVA (Except in swing-out cover model)	•	✓
4 Lifting points for gen sets from 450 kVA and bigger.	✓	•
Preparate for extended fuel tank, fully bomded for leakage protection.	✓	✓
Base frame is prepared for trailer kit installation.	✓	✓
Standard electronic speed governor on engines from 220 kVA (LTP) and up.	✓	✓
Horizontal outlet for hot air	•	✓

AV-700 - VOLVO - TWD 1643 GE

1.500 R.P.M. | 50 Hz

## DSE 7310 MANUAL CONTROL PANEL

### DSE 7310 MANUAL CONTROL PANEL

MANUAL CONTROL, PROTECTION AND DISTRIBUTION panel, assembled on the generator set in metal cabinet with a DSE 7310 engine protection unit.



Image for guidance purposes.

It has the following:

**1** EMERGENCY STOP PUSHBUTTON.

**2** PROTECTIONS:

- Magnetothermal Protection
- Earth Leak Protection
- Protection fuses for control module

AV-700 - VOLVO - TWD 1643 GE

1.500 R.P.M. | 50 Hz

## DSE 7310 MANUAL CONTROL PANEL

- 3 DSE 7310 CONTROL and PROTECTION CENTRE.** It has a digital LCD screen, which provides easy reading of the information regarding the ENGINE, ALTERNATOR and CHARGING.

### READINGS that can be made:

#### ENGINE:

- Coolant temperature
- Oil pressure
- Turning speed (rpm)
- Fuel level
- Battery voltage
- Battery alternator voltage.
- Operating hours
- Number of start-ups

#### ALTERNATOR AND CHARGE:

- Voltages between phases and between phases and neutral.
- Intensities
- Frequency
- Active Power (kW)
- Reactive Power (kVAr)
- Apparent Power (kVA)
- Cos phi
- Active energy meter (kW-h)

### CONTROL of the set:

- START AND STOP the set MANUALLY.
- Possibility of doing it AUTOMATICALLY via START ON SIGNAL.

### PROTECTION of the engine and alternator, with the ALARMS activated:

#### ENGINE:

- Low oil pressure
- High coolant temperature
- Low and High battery Voltage
- Failure of the alternator to charge batteries
- Low fuel level.

#### ALTERNATOR:

- Low and High Voltage
- Low and High Frequency
- Overload due to Intensity (A)
- Short-circuit
- Negative Phase Sequence.
- Power Overload (KW-kVA)
- Load control:
  - 1.Connection and disconnection of artificial loads.
  - 2.Disconnection of non-essential loads

AV-700 - VOLVO - TWD 1643 GE

1.500 R.P.M. | 50 Hz

**DSE 7310 MANUAL CONTROL PANEL**

**OTHER CHARACTERISTICS:**

- The real-time clock provides an exact record of events
- Extensive number of configurable inputs and outputs.
- Configurable alarms and timers.
- USB connectivity
- Fully configurable via software and PC
- Modbus RTU
- Possibility of SMS text messages
- Communications Ethernet, RS 232 and RS 485
- Programmer Clock with multiple maintenance events which can be configured for the optimal operation of the engine. Weekly and/or monthly programming of up to 16 starts and stops per week.

For OPEN sets - Three-phase generators (single phase by request):

CONT . POW.	MAGNETO. PROTECTION (A)	EARTH LEAK PROTECTION	DISTRIBUTION
SET POWER	10 kVA	4P, 16A (B) 1P+N 16 A (C)	Mod. 16A, 300 mA 1 BASE CEE 3P+N+T 16A 1 BASE CEE 2P+T 16 A
	15 kVA	4P, 25A (B) 1P+N 16 A (C)	Mod. 25A, 300 mA 1 BASE CEE 3P+N+T 32A 1 BASE CEE 2P+T 16 A
	20 kVA	4P, 32A (B)	Mod. 32 A, 300 mA POWER TERMINALS
	30 kVA	4P, 50 A (B)	Mod. 63 A, 300 mA POWER TERMINALS
	40 kVA	4P, 63 A (B)	Mod. 63 A, 300 mA POWER TERMINALS
	50 kVA	4P, 80 A (B)	Electronic adjustable POWER TERMINALS
	60 kVA	4P, 100 A (B)	Electronic adjustable POWER TERMINALS
	75-80 kVA	4P, 125 A (B)	Electronic adjustable POWER TERMINALS
	100 kVA	3P, 160 A (B)	Electronic adjustable POWER TERMINALS
	125-170 kVA	3P, 250 A (B)	Electronic adjustable POWER TERMINALS
	180-275 kVA	3P, 400 A (B)	Electronic adjustable OUTPUT DIRECTLY FROM THE CIRCUIT BREAKER
	300-430 kVA	3P, 630 A (B)	Electronic adjustable OUTPUT DIRECTLY FROM THE CIRCUIT BREAKER
	450-550 kVA	3P, 800 A (B)	Electronic adjustable OUTPUT DIRECTLY FROM THE CIRCUIT BREAKER
	570-665 kVA	3P, 1000 A (B)	Electronic adjustable OUTPUT DIRECTLY FROM THE CIRCUIT BREAKER



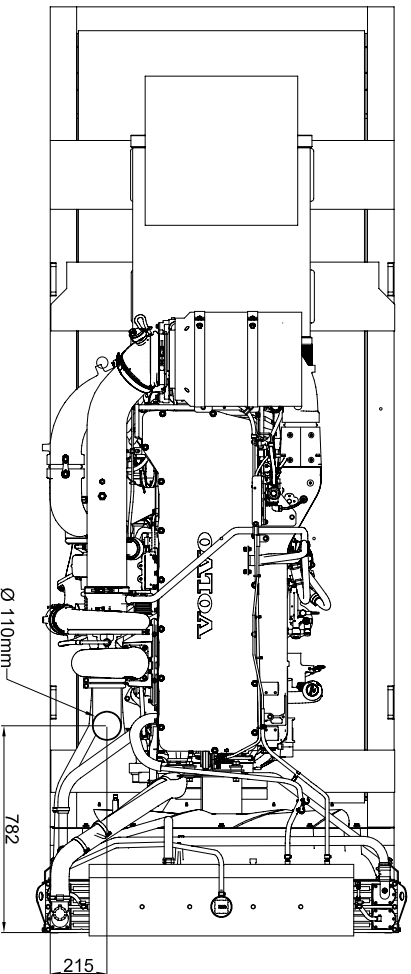
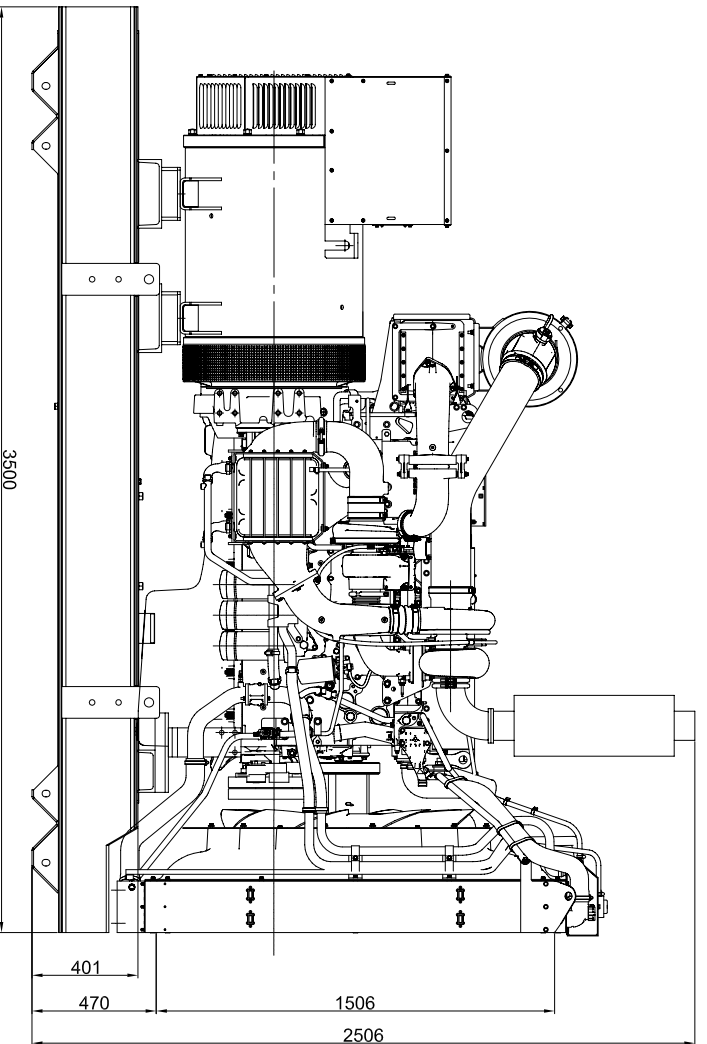
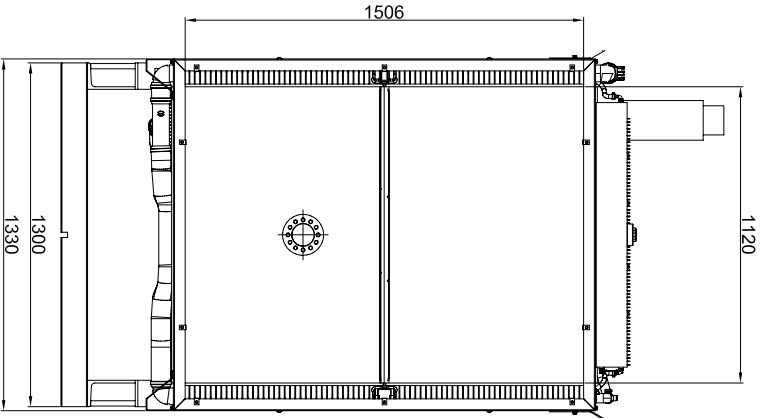

CAPACIDAD DE DEPOSITO = 1023 LTS

		<b>PROYECTO:</b> <b>G.E. EST-STD 620 Kva VOLVO (TAD 1643 GE)</b>	
<small>Las tolerancias o surtir de acuerdo de dibujo, a de todo perfilado, a menos que se indique lo contrario. Dimensiones en milímetros con tolerancia de fabricación sea de 0.20 mm. Dimensiones de 1500 mm.</small>		<small>MATERIAL</small> <small>TOLERANCIA GENERAL</small>	
<b>MODIFICADO</b>	J.S.BELAR	<b>DIBUJADO</b>	U.S.
<b>COMPROBADO</b>	A.L.SOLANO	<b>U.S.</b>	mm
<b>CODIGO</b>		<b>EXPEDIENTE:</b>	
<b>PESO</b>		<b>Nº PLANO</b>	
<b>ESCALA</b>		<b>MARCA</b>	
<b>DENOMINACION:</b>		<b>DIMENSIONES GENERALES</b>	
G.E. EST-STD 620 Kva VOLVO			

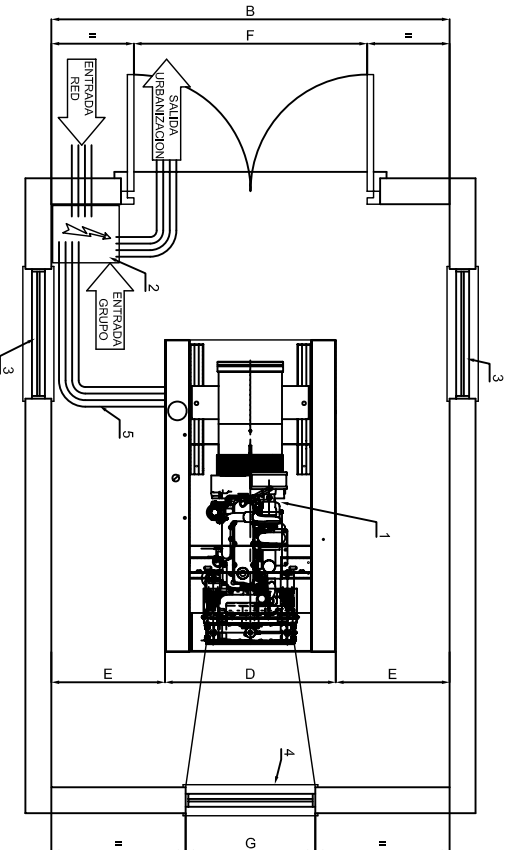
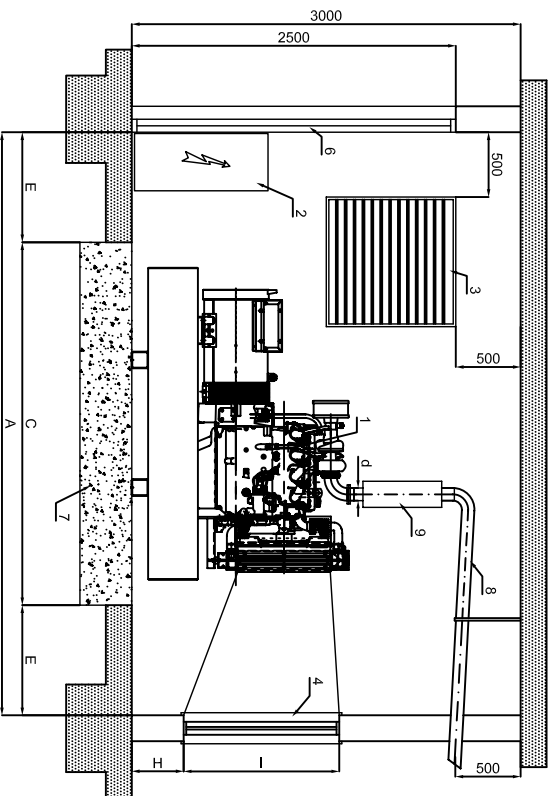

DIMENSIONES DE SALA SEGUN POTENCIA												
POTENCIA	A	B	C	D	E	F	G	H	I	d	PESO	SECCION HUECO ENTRADA AIRE
85 Kva	4050	2930	2050	930	1000	1430	800	450	800	80	1100	2x1,00 m2
105 Kva	4250	2930	2250	930	1000	1430	900	450	900	80	1320	2x1,00 m2
130 Kva	4250	3035	2250	1035	1000	1535	900	450	900	80	1460	2x1,00 m2
150 Kva	4500	3035	2500	1035	1000	1535	900	500	900	80	1620	2x2,00 m2
180 Kva	4500	3035	2500	1035	1000	1535	1000	500	1100	80	1608	2x2,00 m2
200 Kva	4500	3035	2500	1035	1000	1535	1000	500	1100	80	1780	2x2,00 m2
250 Kva	5000	3200	3000	1200	1000	1700	1200	500	1100	80	1950	2x2,50 m2
300 Kva	5000	3200	3000	1200	1000	1700	1300	650	1200	110	2770	2x2,50 m2
350 Kva	5000	3200	3000	1200	1000	1700	1400	650	1300	110	3295	2x3,00 m2
375 Kva	5000	3200	3000	1200	1000	1700	1400	650	1300	110	2770	2x3,00 m2
400 Kva	5000	3200	3000	1200	1000	1700	1500	650	1500	110	3295	2x3,00 m2
450 Kva	5490	3300	3490	1300	1000	1800	1500	725	1500	110	3295	2x3,00 m2
500 Kva	5490	3300	3490	1300	1000	1800	1700	725	1700	110	4030	2x3,50 m2
550 Kva	5490	3300	3490	1300	1000	1800	1700	725	1700	110	4240	2x3,50 m2
620 Kva	5500	3330	3500	1330	1000	1880	1900	725	1900	110	4440	2x4,00 m2

- NOMENCLATURA**
- 1.- GRUPO ELECTROGENO
  - 2.- CUADRO DE CONTROL
  - 3.- HUECO ENTRADA DEL AIRE
  - 4.- TUNEL DE EXPULSION DEL AIRE
  - 5.- BANDEJA PASACABLES
  - 6.- PUERTA DE ACCESO
  - 7.- BASE HORMIGON ARMADO H-175
  - 8.- TUBO DE ESCAPE
  - 9.- SILENCIADOR DE ESCAPE

EL Ø DE LA TUBERIA DE EXTENSION DEL ESCAPE PUEDE SER EL MISMO QUE EL DEL SILENCIADOR HASTA 5 m. PARA DISTANCAS MAYORES DE 5 m. DEBE AUMENTARSE EL Ø DE LA TUBERIA 10 mm POR CADA 10 m MAS DE DISTANCIA ENTRE EL GRUPO ELECTROGENO Y LA SALIDA EXTERIOR

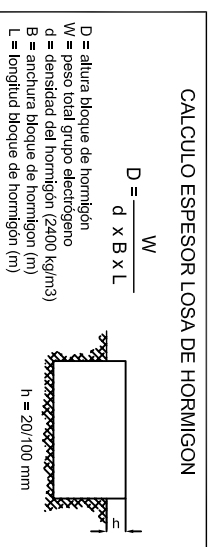

<b>INMESOL</b>		PROYECTOR:		<b>GRUPO ESTATICO ESTANDAR VOLVO</b>			
<small>Las fotografías o copias de este documento, o de sus partes, no pueden ser utilizadas para fines de explotación económica, ni para la reproducción o transformación de esta obra. Queda permitida la impresión en su totalidad o parcialmente para uso personal o para uso interno de una institución de enseñanza.</small>		MODIFICADO	J.S.BELAR	MATERIAL			
REISO	ESCALA	DISEÑADO	J.S.BELAR	TOLERANCIA GENERAL			
		COMPROBADO	A.L.SOLANO	UDS.			
		DENOMINACION:	GRUPOS EST-STD VOLVO				
			DIMENSIONES DE SALA				
				EXPEDIENTE:	Nº PLANO	MARCA	