

**AV-200 - VOLVO - TAD 732 GE**

**1.500 R.P.M. | 50 Hz**

## TECHNICAL SPECIFICATIONS



Model:

**AV-200**

Gen set with manual control panel.

Image for guidance purposes.

ENGINE	MAKE	MODEL
	VOLVO	TAD 732 GE
ALTERNATOR	MODEL	
	MECC-ALTE ECO 38-1SN	

(400 / 230 V)

CONTINUOUS POWER: (PRP "Prime Power" norma ISO 8528-1)	<b>180 kVA</b>
STAND-BY POWER: (LTP "Limited Time Power" norma ISO 8528-1)	<b>200 kVA</b>

### Amperes in the different voltages:

VOLTAGE	HZ	PHASE	COS Ø	PRP KVA/KW	LTP KVA/KW	AMPERAGE
415/240	50	3	0,8	180,0/144,0	198,0/158,4	275,79
400/230	50	3	0,8	180,0/144,0	198,0/158,4	286,13
380/220	50	3	0,8	180,0/144,0	198,0/158,4	301,19
240/139	50	3	0,8	180,0/144,0	198,0/158,4	476,88
230/133	50	3	0,8	180,0/144,0	198,0/158,4	497,61
220/127	50	3	0,8	180,0/144,0	198,0/158,4	520,23

**ELECTRO EXIM SRL**

**ELECTRO EXIM SRL**  
21 Ialomicioarei St., sector 1, code 011277, BUCHAREST - ROMANIA  
Phone: 0040 21 2231347 - 0040 744 755 390 - FAX: 0040 21 2231201  
E-mail: office@electroexim.com - Web: www.electroexim.ro

**AV-200 - VOLVO - TAD 732 GE**

**1.500 R.P.M. | 50 Hz**

## ENGINE CHARACTERISTICS

MAKE	MODEL
VOLVO	TAD 732 GE

### GENERAL DATA

Power PRP (kWm)	160
Power LTP (kWm)	179
No. cylinders	6
Cylinder capacity (L)	7.15
Diameter per stroke (mm)	108 x 130
Compression ratio	18
Cooling system	LIQUID
Injection	DIRECT
Suction	TURBO-INTERC.
Series regulator	ELECTRONIC
Fly wheel coupling	2 -11,5"

### Lubrication system

Oil capacity (L)	34
Oil consumption (%)	0.35
Min. alarm oil pressure (bar)	2

### Ventilation system

Air cooling flow (m3/h)	14040
Combustion air flow (m3/h)	684
Max. back pressure for fan (mbar)	0

### Exhaust system

Exhaust gas flow (m3/h)	1914
Exhaust back pressure (mbar)	50
Temp. exhaust gases (°C)	529

### Electrical system

VDC (V)	24
Battery (Ah)	120
Engine start-up (kW)	5.50

**ELECTRO EXIM SRL**

**ELECTRO EXIM SRL**  
21 Ialomicioarei St., sector 1, code 011277, BUCHAREST - ROMANIA  
Phone: 0040 21 2231347 - 0040 744 755 390 - FAX: 0040 21 2231201  
E-mail: office@electroexim.com - Web: www.electroexim.ro

**AV-200 - VOLVO - TAD 732 GE**

**1.500 R.P.M. | 50 Hz**

## ALTERNATOR CHARACTERISTICS

### MODEL

MECC-ALTE ECO 38-1SN (400 / 230 V)

### GENERAL DATA

Power PRP (kVA)	180
Power LTP (kVA)	198.00
Efficiency Alt. 3/4 %	92.60
Efficiency Alt. 4/4 %	92.40
No. Poles	4
Voltage regulator	DSR
No. wires	12
Insulation	H
Xd (%)	197
X'd (%)	9.70
X	5.50
Degree of protection	IP21

## GENERATOR SET CONSUMPTION

% POWER USED	LITRES/HOUR
50%	21
75%	31
100%	41

## DIMENSIONS, CAPACITIES, APPROXIMATE WEIGHT AND NOISE

LENGTH	DIMENSIONS (MM)	
	WIDTH	HEIGHT
2500	1035	1845
FUEL TANK (LITRES)		WEIGHT (KG)
236		1850.00
NOISE LEVEL (dB (A))		

**AV-200 - VOLVO - TAD 732 GE**

**1.500 R.P.M. | 50 Hz**

## **INMESOL GENERATOR SET**

### **GENERAL DESCRIPTION**

The "INMESOL" generator set is an electrical energy generating machine which is used in places where there **is no mains supply** or when there is a MAINS failure.

The mobile elements, distribution belt, fan, etc., and those parts which reach high temperatures during operation, exhaust manifold, etc, include their corresponding protections, in compliance with the requirements of the Machinery Directive **2006/42**.

### **REGULATIONS**

The machine holds the "CE" marking, and the corresponding Declaration of Conformity is issued with each of them, in which it specifies that the machine complies with **R.D 842/2002 Low Voltage Regulations and with the European Directives:**

- 2006/42 on Safety in Machinery.
- 2006/95/CE on Electrical Safety.
- 2004/108/CE on Electromagnetic Compatibility.
- 2005/88/CE on NOISE EMISSIONS by equipment for outdoor use (for SOUNDPROOF GENERATOR SETS).

**AV-200 - VOLVO - TAD 732 GE**

**1.500 R.P.M. | 50 Hz**

**IN INDUSTRIAL RANGE / SCOPE OF SUPPLY**

		
Engine/alternator monobloc directly connected and installed via silent blocks on a frame made from high tensile electro welded steel profiles that are treated with degreasing liquids and aplicated with a phosphate coat and epoxi paint.	✓	✓
Canopy of steel sheet sound proofed with fireproof rockwool, and treated with degreasing liquids and aplicated with a phosphate coat and epoxi paint.	•	✓
Fuel tank integrated in the base frame provided with fuel level jauge and fuel connections to the engine.	✓	✓
Engine with mechanical engine driven pusher fan.	✓	✓
Industrial silencer with -15 db(A) noise reduction and exhaust outlet tube.	✓	•
Residencial silencer with -35 db(A) noise reduction with exhaust tube and protection cap.	•	✓
Electric control cubicle with control module including protection and reading of electrical meassures engine instrumentation fuel level and engine running hours, etc.	✓	✓
Termal and magnetic circuit breaker and termal and magnetic circuit breaker and earth fault relay.	✓	✓
Battery charge alternator.	✓	✓
Starter battery complete with cables to the engine and pole protection.	✓	✓
Installation prepared for earthing spike (spike not included).	✓	✓
Security protection for heat and moving parts as well as live electrical components.	✓	✓
External emergency stop push button.	✓	✓
Manual engine oil extraction pump.	•	✓
Self excited and auto regulated alternator.	✓	✓
Integrated lifting hook for single point lifting with crane, gensets up to 450 kVA (Except in swing-out cover model)	•	✓
4 Lifting points for gen sets from 450 kVA and bigger.	✓	•
Preparate for extended fuel tank, fully bomded for leakage protection.	✓	✓
Base frame is prepared for trailer kit installation.	✓	✓
Standard electronic speed governor on engines from 220 kVA (LTP) and up.	✓	✓
Horizontal outlet for hot air	•	✓

AV-200 - VOLVO - TAD 732 GE

1.500 R.P.M. | 50 Hz

## DSE 3110 MANUAL CONTROL PANEL

### DSE 3110 MANUAL CONTROL PANEL

MANUAL CONTROL, PROTECTION AND DISTRIBUTION panel, assembled on the generator set in metal cabinet with a DSE 3110 engine protection unit.



It has the following:

Image for guidance purposes.

**1** STARTER SWITCH

**2** EMERGENCY STOP PUSHBUTTON

**3** MEASURING INSTRUMENTS:

- Analogue ammeters
- Analogue voltmeter
- Fuel level indicator.
- Digital Hz display and hour meter (DSE 3110)

AV-200 - VOLVO - TAD 732 GE

1.500 R.P.M. | 50 Hz

## DSE 3110 MANUAL CONTROL PANEL

### 4 SET CONTROL AND ENGINE PROTECTION: DSE 3110, allows:

- START AND STOP the set MANUALLY.
- Possibility of doing it AUTOMATICALLY via START ON SIGNAL
- Digital readings of the operating hours and the Frequency
- Controls the main characteristics of the engine, causing an alarm or stopping the machine:
  - 1.Low and High Voltage (STOP)
  - 2.Low and High Frequency and Speed (STOP)
  - 3.Low Oil Pressure and High Coolant Temperature (STOP)
  - 4.Failure of the Alternator Battery-Charger (ALARM)
  - 5.Low fuel level (ALARM)

### 5 PROTECTIONS:

- Magnetothermal Protections
- Earth Leak Protection
- Protection fuses for control module

AV-200 - VOLVO - TAD 732 GE

1.500 R.P.M. | 50 Hz

**DSE 3110 MANUAL CONTROL PANEL**

For OPEN sets - Three-phase generators (single phase by request):

CONT . POW.	MAGNETO. PROTECTION (A)	EARTH LEAK PROTECTION	DISTRIBUTION
SET POWER	10 kVA	4P, 16A (B) 1P+N 16 A (C)	Mod. 16A, 300 mA 1 BASE CEE 3P+N+T 16A 1 BASE CEE 2P+T 16 A
	15 kVA	4P, 25A (B) 1P+N 16 A (C)	Mod. 25A, 300 mA 1 BASE CEE 3P+N+T 32A 1 BASE CEE 2P+T 16 A
	20 kVA	4P, 32A (B)	Mod. 32 A, 300 mA POWER TERMINALS
	30 kVA	4P, 50 A (B)	Mod. 63 A, 300 mA POWER TERMINALS
	40 kVA	4P, 63 A (B)	Mod. 63 A, 300 mA POWER TERMINALS
	50 kVA	4P, 80 A (B)	Electronic adjustable POWER TERMINALS
	60 kVA	4P, 100 A (B)	Electronic adjustable POWER TERMINALS
	75-80 kVA	4P, 125 A (B)	Electronic adjustable POWER TERMINALS
	100 kVA	3P, 160 A (B)	Electronic adjustable POWER TERMINALS
	125-170 kVA	3P, 250 A (B)	Electronic adjustable POWER TERMINALS
	180-275 kVA	3P, 400 A (B)	Electronic adjustable OUTPUT DIRECTLY FROM THE CIRCUIT BREAKER
	300-430 kVA	3P, 630 A (B)	Electronic adjustable OUTPUT DIRECTLY FROM THE CIRCUIT BREAKER
	450-550 kVA	3P, 800 A (B)	Electronic adjustable OUTPUT DIRECTLY FROM THE CIRCUIT BREAKER
	570-665 kVA	3P, 1000 A (B)	Electronic adjustable OUTPUT DIRECTLY FROM THE CIRCUIT BREAKER



AV-200 - VOLVO - TAD 732 GE

1.500 R.P.M. | 50 Hz

## DSE 3110 MANUAL CONTROL PANEL

### 6 OPTIONAL:

AUTOMATIC PANEL FOR MANUAL GENERATOR: ATS DSE 334

- This panel provides the manual control generator with a reserve operation from the Mains, as the ATS sends the command to start and stop the generator, when it detects a supply failure and when the Mains is restored



Cubicle composed of the electronic control module which is detecting a mains failure and of 2 contactors mechanically and electrically interlocked or a motorized switch controlled by the above electronic controller who are realizing the change of supply from the GEN SET or the MAINS to the load.

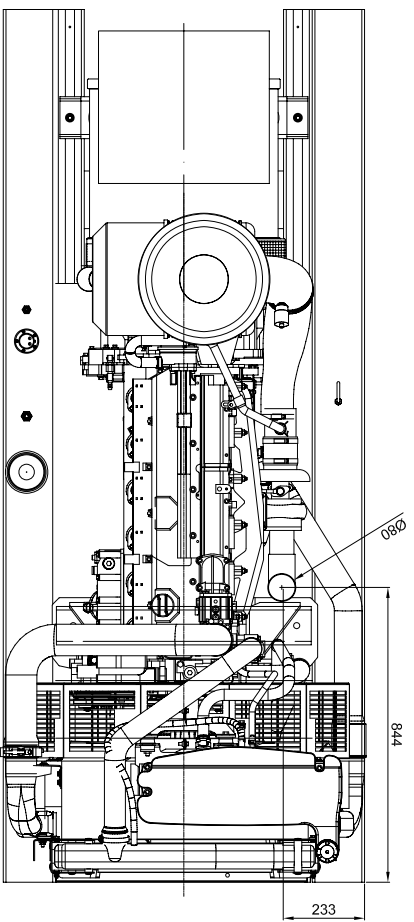
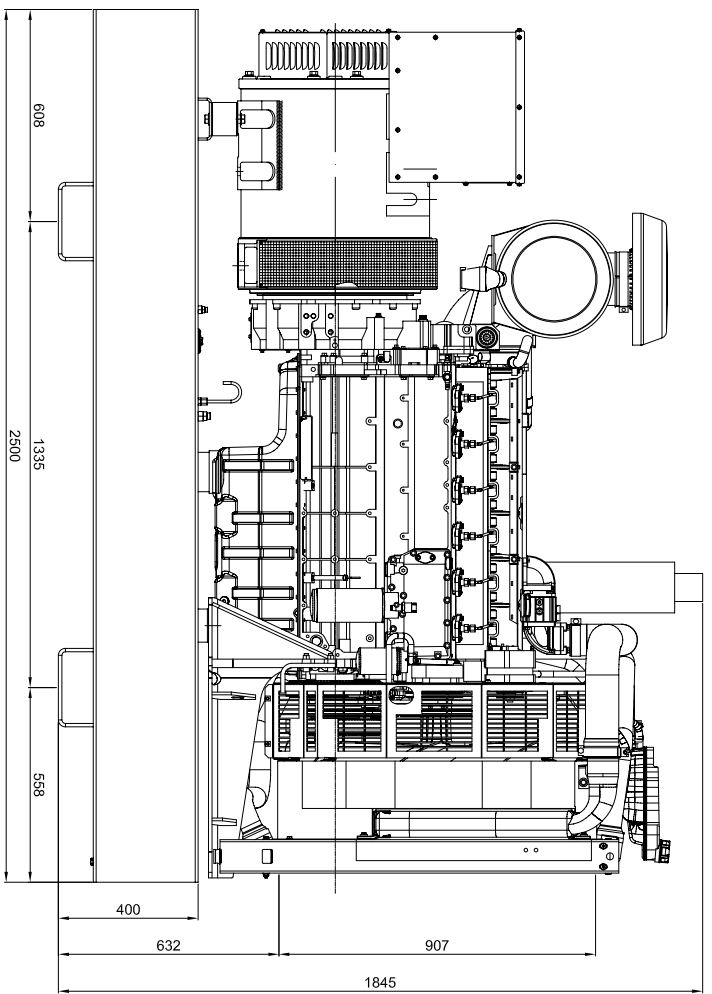
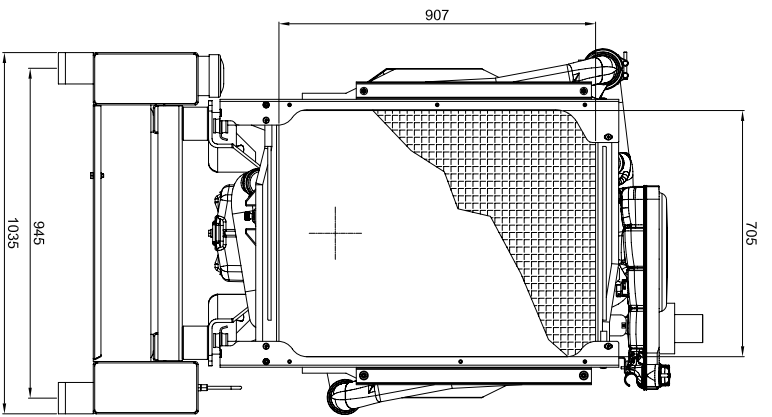

CAPACIDAD DE DEPOSITO = 236 LTS

		PROYECTO: <b>G.E. EST-STD 180 KVA VOLVO (TAD 732 GE)</b>	
<small>Una licencia o copyright en apariencia de copia, a no ser que se indique lo contrario, es una reproducción no autorizada de un documento de propiedad intelectual de INMIESOL S.A. y se prohíbe su uso sin el consentimiento escrito de INMIESOL S.A.</small>			
MODIFICADO	J.G.SEBAST	12-Ago-2011	MATERIAL
DIBUJADO	J.L.SOLANO	12-Ago-2011	TOLERANCIA GENERAL
COMPROBADO			UDS. mm
DENOMINACION:		EXEQUENTE:	
G.E. EST-STD 180 KVA VOLVO		Nº MOD.	
DIMENSIONES GENERALES		Nº PLANO	
PESO		MARCA	
ESCALA			

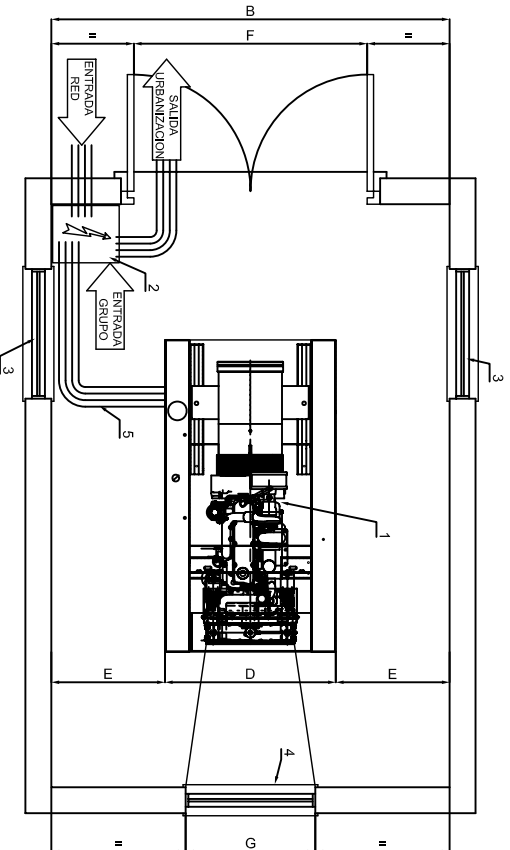
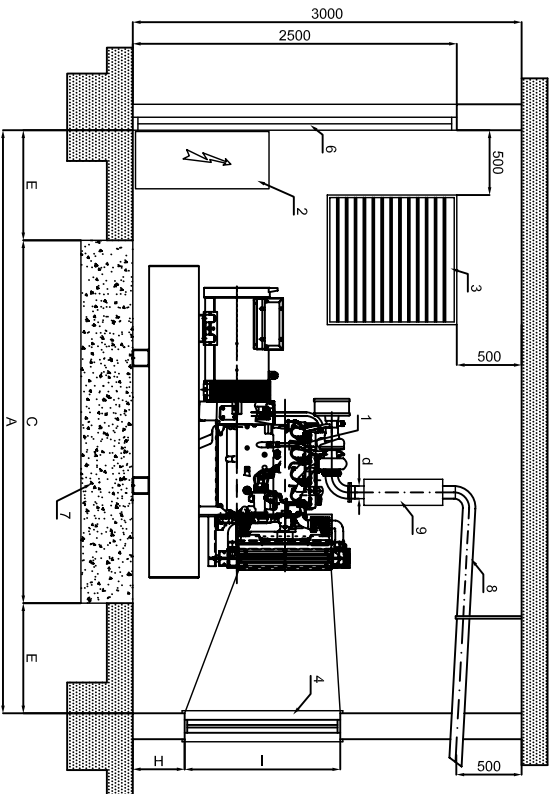

POTENCIA	DIMENSIONES DE SALA SEGUN POTENCIA											PESO	SECCION HUECO ENTRADA AIRE
	A	B	C	D	E	F	G	H	I	d			
85 Kva	4050	2930	2050	930	1000	1430	800	450	800	80	1100	1100	2x1,00 m2
105 Kva	4250	2930	2250	930	1000	1430	900	450	900	80	1320	1320	2x1,00 m2
130 Kva	4250	3035	2250	1035	1000	1535	900	450	900	80	1460	1460	2x1,00 m2
150 Kva	4500	3035	2500	1035	1000	1535	900	500	900	80	1620	1620	2x2,00 m2
180 Kva	4500	3035	2500	1035	1000	1535	1000	500	1100	80	1608	1608	2x2,00 m2
200 Kva	4500	3035	2500	1035	1000	1535	1000	500	1100	80	1780	1780	2x2,00 m2
250 Kva	5000	3200	3000	1200	1000	1700	1200	500	1100	80	1950	1950	2x2,50 m2
300 Kva	5000	3200	3000	1200	1000	1700	1300	650	1200	110	2770	2770	2x2,50 m2
350 Kva	5000	3200	3000	1200	1000	1700	1400	650	1300	110	3295	3295	2x3,00 m2
375 Kva	5000	3200	3000	1200	1000	1700	1400	650	1300	110	2770	2770	2x3,00 m2
400 Kva	5000	3200	3000	1200	1000	1700	1500	650	1500	110	3295	3295	2x3,00 m2
450 Kva	5490	3300	3490	1300	1000	1800	1500	725	1500	110	3295	3295	2x3,00 m2
500 Kva	5490	3300	3490	1300	1000	1800	1700	725	1700	110	4030	4030	2x3,50 m2
550 Kva	5490	3300	3490	1300	1000	1800	1700	725	1700	110	4240	4240	2x3,50 m2
620 Kva	5500	3330	3500	1330	1000	1880	1900	725	1900	110	4440	4440	2x4,00 m2

- NOMENCLATURA**
- 1.- GRUPO ELECTROGENO
  - 2.- CUADRO DE CONTROL
  - 3.- HUECO ENTRADA DEL AIRE
  - 4.- TUNEL DE EXPULSION DEL AIRE
  - 5.- BANDEJA PASACABLES
  - 6.- PUERTA DE ACCESO
  - 7.- BASE HORMIGON ARMADO H-175
  - 8.- TUBO DE ESCAPE
  - 9.- SILENCIADOR DE ESCAPE

EL Ø DE LA TUBERIA DE EXTENSION DEL ESCAPE PUEDE SER EL MISMO QUE EL DEL SILENCIADOR HASTA 5 m. PARA DISTANCAS MAYORES DE 5 m. DEBE AUMENTARSE EL Ø DE LA TUBERIA 10 mm POR CADA 10 m MAS DE DISTANCIA ENTRE EL GRUPO ELECTROGENO Y LA SALIDA EXTERIOR

**CALCULO ESPESOR LOSA DE HORMIGON**

$$D = \frac{W}{d \times B \times L}$$

D = altura bloque de hormigon  
W = peso total grupo electrogeno  
d = densidad del hormigon (2400 kg/m<sup>3</sup>)  
B = anchura bloque de hormigon (m)  
L = longitud bloque de hormigon (m)

h = 20/100 mm

		<b>GRUPO ESTATICO ESTANDAR VOLVO</b>	
PROYECTO:		MATERIAL:	
MODIFICADO:	J.S.BELAR	07-Sep-2011	
DIBUJADO:	J.S.BELAR	03-Mar-2006	
COMPROBADO:	A.L.SOLANO	07-Sep-2011	
DENOMINACION:	GRUPOS EST-STD VOLVO		
RESO:	DIMENSIONES DE SALA		
ESCALA:			