

**AD-220 - DEUTZ - BF6M 1013 FC G2**

**1.500 R.P.M. | 50 Hz**

## TECHNICAL SPECIFICATIONS

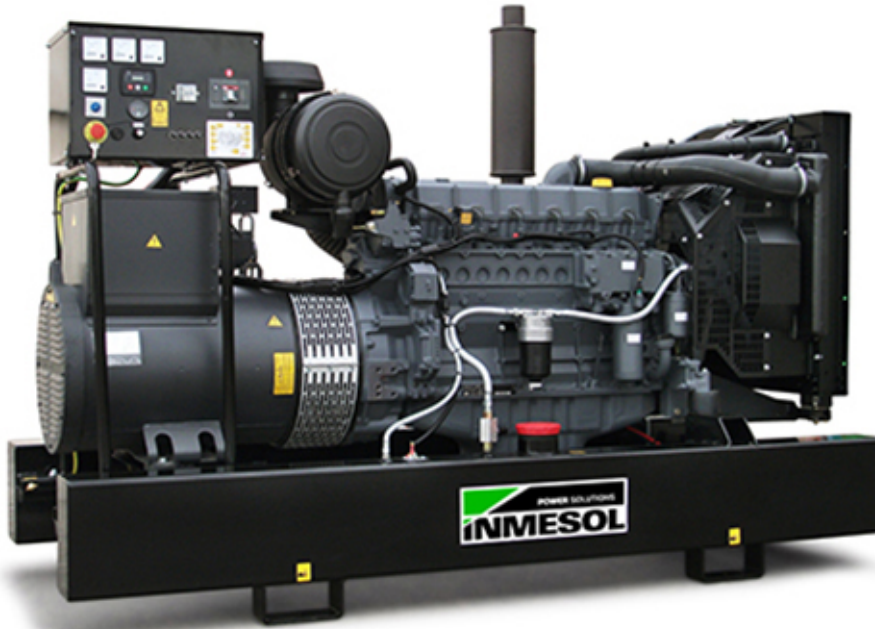

Model:

**AD-220**

Gen set with manual control panel.

Image for guidance purposes.

ENGINE	MAKE	MODEL
	DEUTZ	BF6M 1013 FC G2
ALTERNATOR	MODEL	
	MECC-ALTE ECO 38-2SN	

(400 / 230 V)

CONTINUOUS POWER: (PRP "Prime Power" norma ISO 8528-1)	<b>200 kVA</b>
STAND-BY POWER: (LTP "Limited Time Power" norma ISO 8528-1)	<b>220 kVA</b>

### Amperes in the different voltages:

VOLTAGE	HZ	PHASE	COS Ø	PRP KVA/KW	LTP KVA/KW	AMPERAGE
415/240	50	3	0,8	200,0/160,0	220,0/176,0	306,43
400/230	50	3	0,8	200,0/160,0	220,0/176,0	317,92
380/220	50	3	0,8	200,0/160,0	220,0/176,0	334,65
240/139	50	3	0,8	200,0/160,0	220,0/176,0	529,87
230/133	50	3	0,8	200,0/160,0	220,0/176,0	552,9
220/127	50	3	0,8	200,0/160,0	220,0/176,0	578,03

**ELECTRO EXIM SRL**

**ELECTRO EXIM SRL**  
21 Ialomicioarei St., sector 1, code 011277, BUCHAREST - ROMANIA  
Phone: 0040 21 2231347 - 0040 744 755 390 - FAX: 0040 21 2231201  
E-mail: office@electroexim.com - Web: www.electroexim.ro

**AD-220 - DEUTZ - BF6M 1013 FC G2**

**1.500 R.P.M. | 50 Hz**

## ENGINE CHARACTERISTICS

MAKE	MODEL
DEUTZ	BF6M 1013 FC G2

### GENERAL DATA

Power PRP (kWm)	176.00
Power LTP (kWm)	193.80
No. cylinders	6
Cylinder capacity (L)	7.15
Diameter per stroke (mm)	108 x 130
Compression ratio	18.10
Cooling system	LIQUID
Injection	DIRECT
Suction	TURBO
Series regulator	ELECTRONIC
Fly wheel coupling	2 - 11,5"

### Lubrication system

Oil capacity (L)	20
Oil consumption (%)	0.30
Min. alarm oil pressure (bar)	2.70

### Ventilation system

Air cooling flow (m3/h)	11520
Combustion air flow (m3/h)	745.60
Max. back pressure for fan (mbar)	0

### Exhaust system

Exhaust gas flow (m3/h)	2112
Exhaust back pressure (mbar)	30
Temp. exhaust gases (°C)	530

### Electrical system

VDC (V)	12
Battery (Ah)	120
Engine start-up (kW)	3

**ELECTRO EXIM SRL**

**ELECTRO EXIM SRL**  
 21 Ialomicioarei St., sector 1, code 011277, BUCHAREST - ROMANIA  
 Phone: 0040 21 2231347 - 0040 744 755 390 - FAX: 0040 21 2231201  
 E-mail: office@electroexim.com - Web: www.electroexim.ro

**AD-220 - DEUTZ - BF6M 1013 FC G2**

**1.500 R.P.M. | 50 Hz**

## ALTERNATOR CHARACTERISTICS

### MODEL

MECC-ALTE ECO 38-2SN (400 / 230 V)

### GENERAL DATA

Power PRP (kVA)	200
Power LTP (kVA)	220
Efficiency Alt. 3/4 %	92.90
Efficiency Alt. 4/4 %	92.70
No. Poles	4
Voltage regulator	DSR
No. wires	12
Insulation	H
Xd (%)	200
X'd (%)	11
X	5.90
Degree of protection	IP21

## GENERATOR SET CONSUMPTION

% POWER USED	LITRES/HOUR
50%	25.30
75%	37.70
100%	50.80

## DIMENSIONS, CAPACITIES, APPROXIMATE WEIGHT AND NOISE

LENGTH	DIMENSIONS (MM)	
	WIDTH	HEIGHT
2500	1035	1840
FUEL TANK (LITRES)		WEIGHT (KG)
236		1820.00
NOISE LEVEL (dB (A))		

**ELECTRO EXIM SRL**

**ELECTRO EXIM SRL**  
21 Ialomicioarei St., sector 1, code 011277, BUCHAREST - ROMANIA  
Phone: 0040 21 2231347 - 0040 744 755 390 - FAX: 0040 21 2231201  
E-mail: office@electroexim.com - Web: www.electroexim.ro

**AD-220 - DEUTZ - BF6M 1013 FC G2**

**1.500 R.P.M. | 50 Hz**

## **INMESOL GENERATOR SET**

### **GENERAL DESCRIPTION**

The "INMESOL" generator set is an electrical energy generating machine which is used in places where there **is no mains supply** or when there is a MAINS failure.

The mobile elements, distribution belt, fan, etc., and those parts which reach high temperatures during operation, exhaust manifold, etc, include their corresponding protections, in compliance with the requirements of the Machinery Directive **2006/42**.

### **REGULATIONS**

The machine holds the "CE" marking, and the corresponding Declaration of Conformity is issued with each of them, in which it specifies that the machine complies with **R.D 842/2002 Low Voltage Regulations and with the European Directives:**

- 2006/42 on Safety in Machinery.
- 2006/95/CE on Electrical Safety.
- 2004/108/CE on Electromagnetic Compatibility.
- 2005/88/CE on NOISE EMISSIONS by equipment for outdoor use (for SOUNDPROOF GENERATOR SETS).

**AD-220 - DEUTZ - BF6M 1013 FC G2**

**1.500 R.P.M. | 50 Hz**

**IN INDUSTRIAL RANGE / SCOPE OF SUPPLY**

		
Engine/alternator monobloc directly connected and installed via silent blocks on a frame made from high tensile electro welded steel profiles that are treated with degreasing liquids and aplicated with a phosphate coat and epoxi paint.	<input checked="" type="checkbox"/>	<input checked="" type="checkbox"/>
Canopy of steel sheet sound proofed with fireproof rockwool, and treated with degreasing liquids and aplicated with a phosphate coat and epoxi paint.	<input type="checkbox"/>	<input checked="" type="checkbox"/>
Fuel tank integrated in the base frame provided with fuel level jauge and fuel connections to the engine.	<input checked="" type="checkbox"/>	<input checked="" type="checkbox"/>
Engine with mechanical engine driven pusher fan.	<input checked="" type="checkbox"/>	<input checked="" type="checkbox"/>
Industrial silencer with -15 db(A) noise reduction and exhaust outlet tube.	<input checked="" type="checkbox"/>	<input type="checkbox"/>
Residencial silencer with -35 db(A) noise reduction with exhaust tube and protection cap.	<input type="checkbox"/>	<input checked="" type="checkbox"/>
Electric control cubicle with control module including protection and reading of electrical meassures engine instrumentation fuel level and engine running hours, etc.	<input checked="" type="checkbox"/>	<input checked="" type="checkbox"/>
Termal and magnetic circuit breaker and termal and magnetic circuit breaker and earth fault relay.	<input checked="" type="checkbox"/>	<input checked="" type="checkbox"/>
Battery charge alternator.	<input checked="" type="checkbox"/>	<input checked="" type="checkbox"/>
Starter battery complete with cables to the engine and pole protection.	<input checked="" type="checkbox"/>	<input checked="" type="checkbox"/>
Installation prepared for earthing spike (spike not included).	<input checked="" type="checkbox"/>	<input checked="" type="checkbox"/>
Security protection for heat and moving parts as well as live electrical components.	<input checked="" type="checkbox"/>	<input checked="" type="checkbox"/>
External emergency stop push button.	<input checked="" type="checkbox"/>	<input checked="" type="checkbox"/>
Manual engine oil extraction pump.	<input type="checkbox"/>	<input checked="" type="checkbox"/>
Self excited and auto regulated alternator.	<input checked="" type="checkbox"/>	<input checked="" type="checkbox"/>
Integrated lifting hook for single point lifting with crane, gensets up to 450 kVA (Except in swing-out cover model)	<input type="checkbox"/>	<input checked="" type="checkbox"/>
4 Lifting points for gen sets from 450 kVA and bigger.	<input checked="" type="checkbox"/>	<input type="checkbox"/>
Preparate for extended fuel tank, fully bomded for leakage protection.	<input checked="" type="checkbox"/>	<input checked="" type="checkbox"/>
Base frame is prepared for trailer kit installation.	<input checked="" type="checkbox"/>	<input checked="" type="checkbox"/>
Standard electronic speed governor on engines from 220 kVA (LTP) and up.	<input checked="" type="checkbox"/>	<input checked="" type="checkbox"/>
Horizontal outlet for hot air	<input type="checkbox"/>	<input checked="" type="checkbox"/>

AD-220 - DEUTZ - BF6M 1013 FC G2

1.500 R.P.M. | 50 Hz

## DSE 3110 MANUAL CONTROL PANEL

### DSE 3110 MANUAL CONTROL PANEL

MANUAL CONTROL, PROTECTION AND DISTRIBUTION panel, assembled on the generator set in metal cabinet with a DSE 3110 engine protection unit.



It has the following:

Image for guidance purposes.

**1** STARTER SWITCH

**2** EMERGENCY STOP PUSHBUTTON

**3** MEASURING INSTRUMENTS:

- Analogue ammeters
- Analogue voltmeter
- Fuel level indicator.
- Digital Hz display and hour meter (DSE 3110)

AD-220 - DEUTZ - BF6M 1013 FC G2

1.500 R.P.M. | 50 Hz

## DSE 3110 MANUAL CONTROL PANEL

### 4 SET CONTROL AND ENGINE PROTECTION: DSE 3110, allows:

- START AND STOP the set MANUALLY.
- Possibility of doing it AUTOMATICALLY via START ON SIGNAL
- Digital readings of the operating hours and the Frequency
- Controls the main characteristics of the engine, causing an alarm or stopping the machine:
  - 1.Low and High Voltage (STOP)
  - 2.Low and High Frequency and Speed (STOP)
  - 3.Low Oil Pressure and High Coolant Temperature (STOP)
  - 4.Failure of the Alternator Battery-Charger (ALARM)
  - 5.Low fuel level (ALARM)

### 5 PROTECTIONS:

- Magnetothermal Protections
- Earth Leak Protection
- Protection fuses for control module

AD-220 - DEUTZ - BF6M 1013 FC G2

1.500 R.P.M. | 50 Hz

**DSE 3110 MANUAL CONTROL PANEL**

For OPEN sets - Three-phase generators (single phase by request):

CONT . POW.	MAGNETO. PROTECTION (A)	EARTH LEAK PROTECTION	DISTRIBUTION
SET POWER	10 kVA	4P, 16A (B) 1P+N 16 A (C)	Mod. 16A, 300 mA 1 BASE CEE 3P+N+T 16A 1 BASE CEE 2P+T 16 A
	15 kVA	4P, 25A (B) 1P+N 16 A (C)	Mod. 25A, 300 mA 1 BASE CEE 3P+N+T 32A 1 BASE CEE 2P+T 16 A
	20 kVA	4P, 32A (B)	Mod. 32 A, 300 mA POWER TERMINALS
	30 kVA	4P, 50 A (B)	Mod. 63 A, 300 mA POWER TERMINALS
	40 kVA	4P, 63 A (B)	Mod. 63 A, 300 mA POWER TERMINALS
	50 kVA	4P, 80 A (B)	Electronic adjustable POWER TERMINALS
	60 kVA	4P, 100 A (B)	Electronic adjustable POWER TERMINALS
	75-80 kVA	4P, 125 A (B)	Electronic adjustable POWER TERMINALS
	100 kVA	3P, 160 A (B)	Electronic adjustable POWER TERMINALS
	125-170 kVA	3P, 250 A (B)	Electronic adjustable POWER TERMINALS
	180-275 kVA	3P, 400 A (B)	Electronic adjustable OUTPUT DIRECTLY FROM THE CIRCUIT BREAKER
	300-430 kVA	3P, 630 A (B)	Electronic adjustable OUTPUT DIRECTLY FROM THE CIRCUIT BREAKER
	450-550 kVA	3P, 800 A (B)	Electronic adjustable OUTPUT DIRECTLY FROM THE CIRCUIT BREAKER
	570-665 kVA	3P, 1000 A (B)	Electronic adjustable OUTPUT DIRECTLY FROM THE CIRCUIT BREAKER



AD-220 - DEUTZ - BF6M 1013 FC G2

1.500 R.P.M. | 50 Hz

## DSE 3110 MANUAL CONTROL PANEL

### 6 OPTIONAL:

AUTOMATIC PANEL FOR MANUAL GENERATOR: ATS DSE 334

- This panel provides the manual control generator with a reserve operation from the Mains, as the ATS sends the command to start and stop the generator, when it detects a supply failure and when the Mains is restored



Cubicle composed of the electronic control module which is detecting a mains failure and of 2 contactors mechanically and electrically interlocked or a motorized switch controlled by the above electronic controller who are realizing the change of supply from the GEN SET or the MAINS to the load.

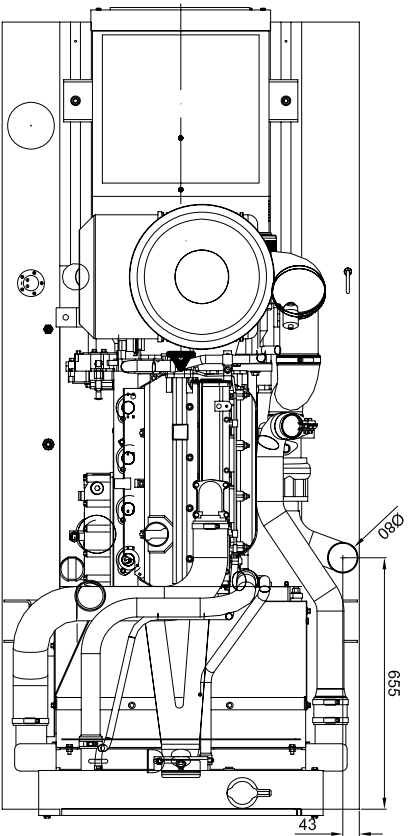
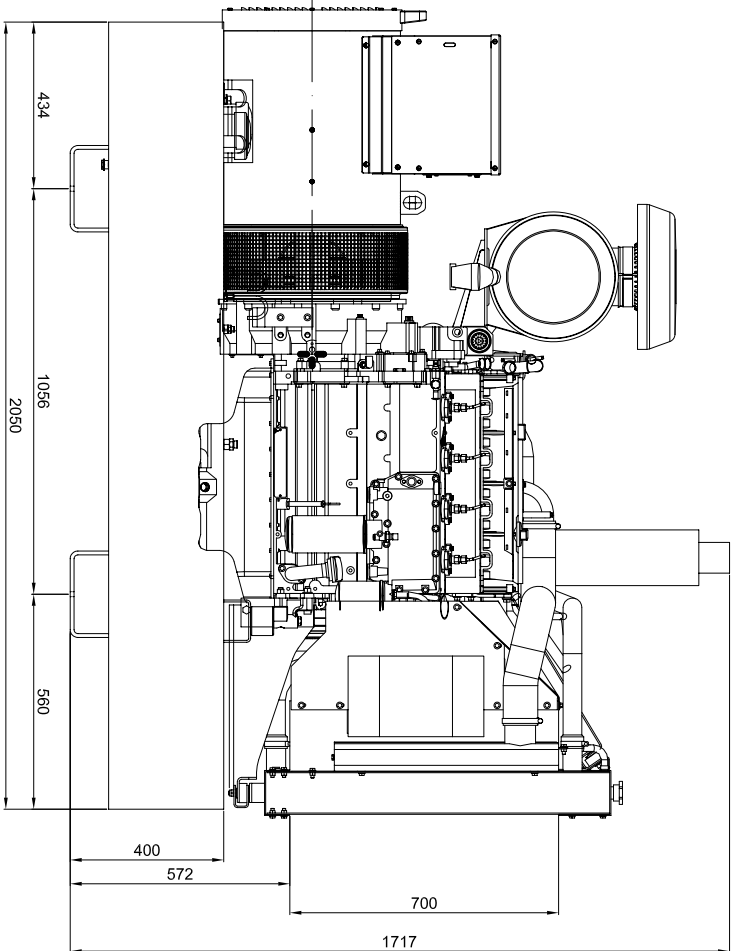
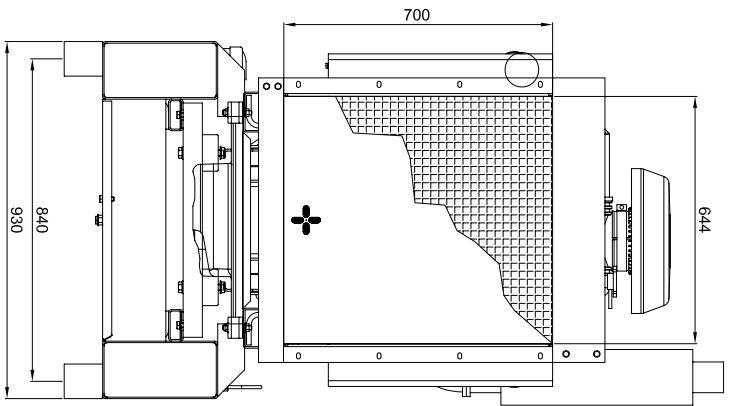

CAPACIDAD DE DEPOSITO = 211,5 LTS

		<p>Las tolerancias o surtidos de aparatos de origen, a de fabricacion, se especifican en el dibujo. En caso de haber modificaciones, se avisara con la debida anticipacion. Se autoriza a los clientes a solicitar modificaciones en los detalles de los aparatos, siempre que no afecten a la seguridad de funcionamiento de los mismos.</p>	
PROYECTO:	G.E. EST-STD 105 Kva DEUTZ (AGUA)		
MODIFICADO	J.S.BELAR	12-Ago-2011	MATERIAL
DIBUJADO	J.S.BELAR	12-Ago-2011	TOLERANCIA GENERAL
COMPROBADO	A.L.SOLANO	12-Ago-2011	UDS.
DENOMINACION:	G.E. EST-STD 105 Kva DEUTZ		
ESCALA	DIMENSIONES GENERALES		
			EXPEDIENTE:
			Nº MOD.
			Nº PLANO
			MARCA

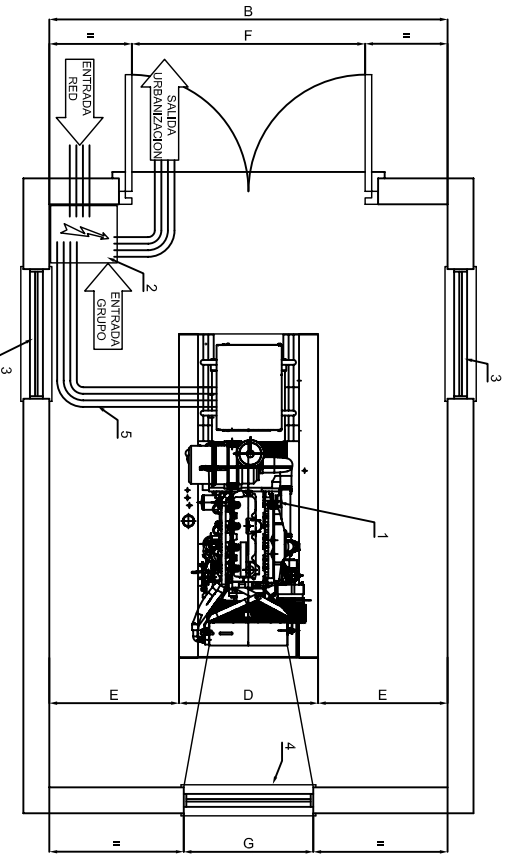
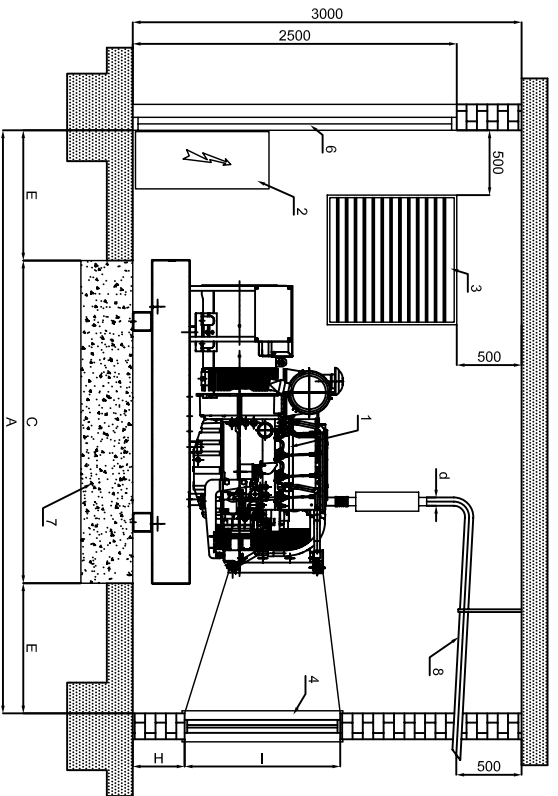

DIMENSIONES DE SALA SEGUN POTENCIA												
POTENCIA	A	B	C	D	E	F	G	H	I	d	PESO	SECCION HUECO ENTRADA AIRE
30 Kva	3700	2300	1700	730	1000	1250	700	400	600	50	620 kg	2 x 0.50 m <sup>2</sup>
40 Kva	3700	2300	1700	730	1000	1250	700	500	600	80	700 kg	2 x 0.50 m <sup>2</sup>
60 Kva	3900	2500	1900	900	1000	1400	700	500	600	80	1000 kg	2 x 0.50 m <sup>2</sup>
85 Kva	4050	2500	2050	930	1000	1430	800	500	700	80	1100 kg	2 x 0.60 m <sup>2</sup>
105 Kva	4250	2500	2250	930	1000	1430	800	500	800	80	1320 kg	2 x 0.80 m <sup>2</sup>
130 Kva	4357	2500	2357	1035	1000	1535	800	500	800	80	1460 kg	2 x 0.80 m <sup>2</sup>
150 Kva	4500	2500	2500	1035	1000	1535	800	500	800	80	1620 kg	2 x 0.90 m <sup>2</sup>
200 Kva	4500	2500	2500	1035	1000	1535	900	500	900	110	1740 kg	2 x 1.00 m <sup>2</sup>
250 Kva	5000	2500	3000	1200	1000	1700	900	500	900	110	2200 kg	2 x 1.00 m <sup>2</sup>
312 Kva	4750	2500	2750	1515	1000	2015	1000	500	1100	2x110	2940 kg	2 x 1.20 m <sup>2</sup>
380 Kva	4750	3000	2750	1515	1000	2015	1300	500	1300	2x110	3360 kg	2 x 2.50 m <sup>2</sup>
429 Kva	5000	3000	3000	1815	1000	2315	1300	500	1300	2x110	3700 kg	2 x 2.50 m <sup>2</sup>
500 Kva	5000	3000	3000	1815	1000	2315	1300	500	1300	2x110	3920 kg	2 x 2.50 m <sup>2</sup>

- NOMENCLATURA**
- 1.- GRUPO ELECTROGENO
  - 2.- CUADRO DE CONTROL
  - 3.- HUECO ENTRADA DEL AIRE
  - 4.- TUNEL DE EXPULSION DEL AIRE
  - 5.- BANDEJA PASACABLES
  - 6.- PUERTA DE ACCESO
  - 7.- BASE HORMIGON ARMADO H-175
  - 8.- TUBO DE ESCAPE
  - 9.- MANGUITO FLEXIBLE
  - 10.- SILENCIADOR DE ESCAPE

EL Ø DE LA TUBERIA DE EXTENSION DEL ESCAPE PUEDE SER EL MISMO QUE EL DEL SILENCIADOR HASTA 5 m. PARA DISTANCAS MAYORES DE 5 m. DEBE AUMENTARSE EL Ø DE LA TUBERIA 10 mm POR CADA 10 m MAS DE DISTANCIA ENTRE EL GRUPO ELECTROGENO Y LA SALIDA EXTERIOR

**CALCULO ESPESOR LOSA DE HORMIGON**

$$D = \frac{W}{d \times B \times L}$$

D = altura bloque de hormigon  
W = peso total grupo electrogeno  
d = densidad del hormigon (2400 kg/m<sup>3</sup>)  
B = anchura bloque de hormigon (m)  
L = longitud bloque de hormigon (m)

h = 20/100 mm

**INMESOL** NEWLINE SOLUTIONS

PROYECTO: **GRUPO ESTATICO ESTANDAR DEUTZ**

MODIFICADO	J.S.BELAR	07-Sep-2011	MATERIAL
DIBUJADO	J.S.BELAR	03-Mar-2006	TOLERANCIA GENERAL
COMPROBADO	A.L.SOLANO	07-Sep-2011	UDS.

GRUPOS EST-STD DEUTZ  
DIMENSIONES DE SALA

ESCALA